

DRAWER SHEET RACK

Sheet rack with 8 to 12 roll-out drawers



The Skanveir drawer sheet rack keeps your different sheet sizes in neat order, separated in compartments of pull out drawers. The system offers a dramatically increased storage density and ergonomical and rapid handling of sheets.

The drawers pull out to full extension, enabling the vacuum lifter to grip directly from above. The practical solution of drawers - centering and fitted with roller bearings - allows easy moving of sheet packs up to 3000 kg.

Advantages

- Substantial saving in floor space
- Eliminates damage to sheets
- Rapid sheet handling
- Ergonomic to operate



The centered drawers can be pulled out easily. Sheets are ergonomically unloaded with Skanveir vacuum lifter.

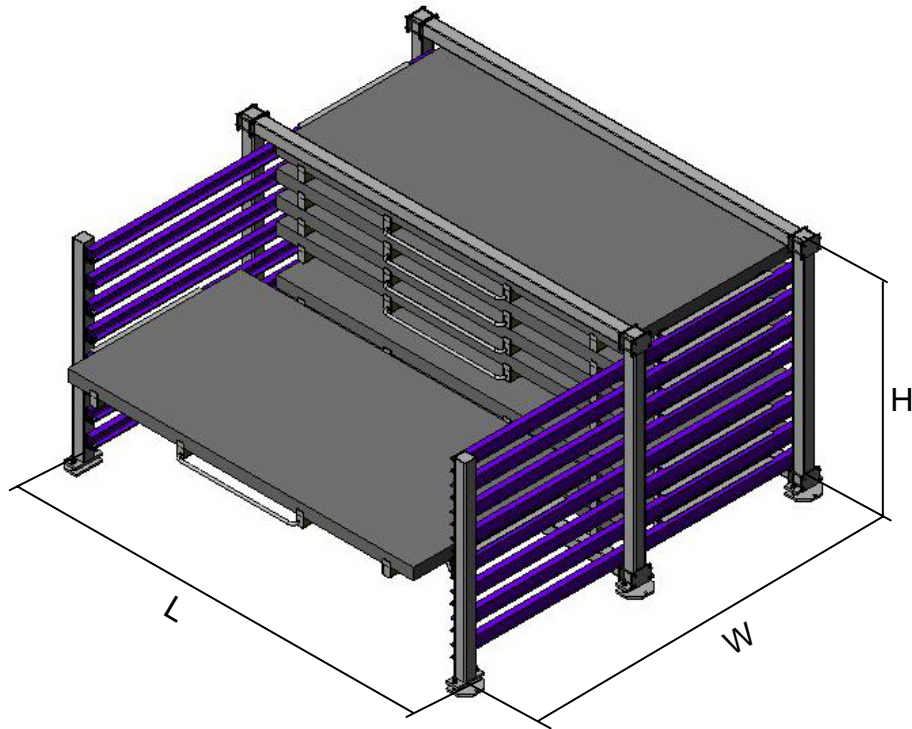

Technical data / Sheet rack for max. sheet size 1,5 x 3 m

Technical data	L8				L10				L12			
Drawer nom. load / kg	1500	2000	2500	3000	1500	2000	2500	3000	1000	1500	2000	2500
Number of drawers / pcs	8				10				12			
Drawer height / mm	65	80	95	110	65	80	95	110	50	65	80	95
Rack height H / mm	1550	1650	1760	1860	1840	1970	2110	2240	1960	2130	2290	2460
Rack length L / mm	3412				3412				3412			
Rack width W / mm	3170				3170				3170			



Dumbo vacuum lifter combined with Skanveir drawer sheet rack is an optimum solution for sheet handling.

Flat material storage

Applicable for

- Steel sheets and plates
- Aluminium
- Plastic
- Plywood
- Other flat material

Skanveir Oy manufactures vacuum and magnetic lifters and portals for plate, element, panel and timber handling. The company has over 25 years of experience in it's field. The customers are mostly found in metal working companies, steel service centres, shipyards, element factories and sawmills.